

Precision Monolithics Inc.

APPLICATION NOTE 115

The SSM-2015 differential amplifier is utilized in a transformerless, active-balanced input amplifier. The circuit shown in Figure 1 provides a microphone preamplifier design with excellent performance and low noise. The design features a transformerless preamplifier circuit with true-balanced input, 1500Ω input loading, phantom microphone powering, and high common-mode rejection. The design shown also includes a twelve position gain selector, or for fixed gain usage, component value calculations.

The design includes microphone input loading of 1500Ω, but the load resistor can be changed to accommodate other applications. Input loading is capacitive reactive at higher frequencies to attenuate unwanted RF and ultrasonic voltages at the input terminals.

The phantom microphone powering circuit provides power for condenser microphones that require 24 to 48 volts DC. The zener diodes CR₁, CR₂, CR₃, and CR₄ protect the input transistors of the SSM-2015 when connecting the microphone to the preamplifier circuit.

The common-mode voltage range is ±5.5 volts. Its common-mode rejection is optimized for most applications by the true-balanced and differential input topology of the SSM-2015. A balanced single pole low-pass filter at the input terminals provides protection for the circuit from radio frequency interference and prevents slewing of the SSM-2015 amplifier. The output circuit topology is complementary bipolar producing 6V/μs slew rate, and able to drive a 2kΩ unbalanced load.

The circuit design incorporates a gain switch with twelve (12) calculated gain settings. For an output voltage of -10dBu, the microphone amplifier circuit has an input sensitivity range of -65dBu to -27.5dBu, and an output headroom of 33dB. The overall circuit gain is adjustable from 27.5dB to 55dB in 2.5dB steps.

SW	G _{dB}	e _{IN} (dB)	R _G	VALUE (Ω)
1	27.5	-37.5	R ₁₅	1.00k
2	30	-40	R ₁₆	715
3	32.5	-42.5	R ₁₇	511
4	35	-45	R ₁₈	374
5	37.5	-47.5	R ₁₉	280
6	40	-50	R ₂₀	205
7	42.5	-52.5	R ₂₁	154
8	45	-55	R ₂₂	115
9	47.5	-57.5	R ₂₃	86.6
10	50	-60	R ₂₄	63.4
11	52.5	-62.5	R ₂₅	47.5
12	55	-65	R ₂₆	35.7

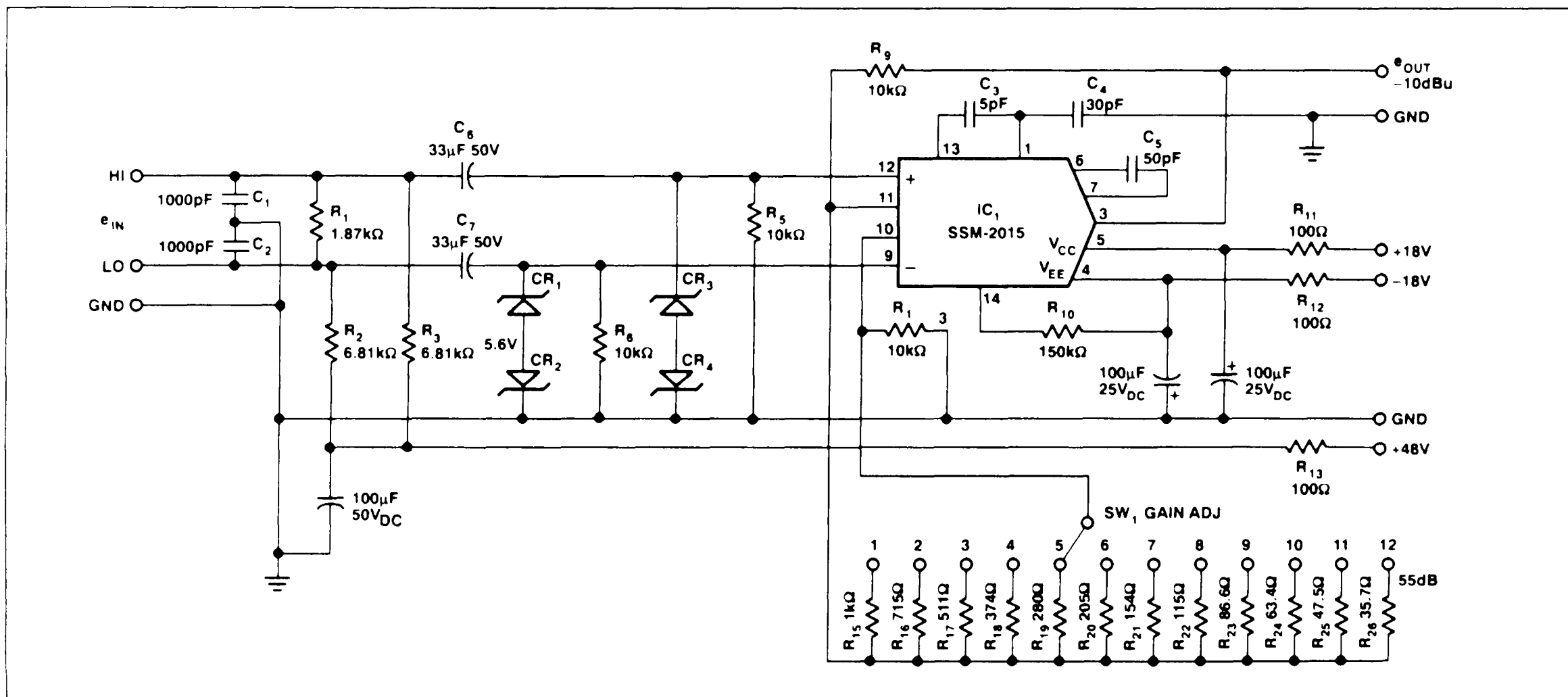

FIGURE 1

SSM-2015 input circuitry utilizes two identical low noise bipolar transistors, with access to the emitters that provide the gain adjustment. R_G (R_{15} through R_{26}) sets the amplifiers gain using the equation:

$$\text{Gain} = 3.5 + \left(\frac{20 \times 10^3}{R_G} \right) \quad \text{for } R_9, \text{ \& } R_{13} = 10.0\text{k}\Omega$$

Unspecified gain can be calculated from the equation:

$$\text{Gain}_{\text{dB}} = 20 \log \left[3.5 + \left(\frac{20 \times 10^3}{R_G} \right) \right]$$

The frequency response amplitude is $\pm 0.1\text{dB}$ from 20 to 20,000Hz, and THD + noise of better than 0.03% over the gain range described with a typical EIN (Equivalent Input Noise) of -124dBu .

The transformerless microphone preamplifier circuit described above demonstrates real-world usage refinements and includes most operational features required by equipment designers.

TABLE 1: Circuit Performance Specifications

Frequency Response (20Hz to 20kHz)	$\pm 0.1\text{dB}$
THD + Noise (@ +23dBu, 20Hz to 20kHz)	0.03%
IMD (@ +23dBu, SMPTE 60Hz & 4kHz, 4:1)	0.05%
EIN (Equivalent Input Noise, 150 Ω source)	-124dB
CMR (Common-Mode Rejection at 1kHz)	105dB
Slew Rate	6V/ μs
Output Voltage (2k Ω load)	+23dBu or 11V _{RMS}
Output Headroom (2k Ω load, -10dBu nominal)	33dB